



# K&SIBASIC

SIMPLE ENERGY

## Inverter Generator

KSB 55i

KSB 80iE-1/3

KSB 110iE-1/3

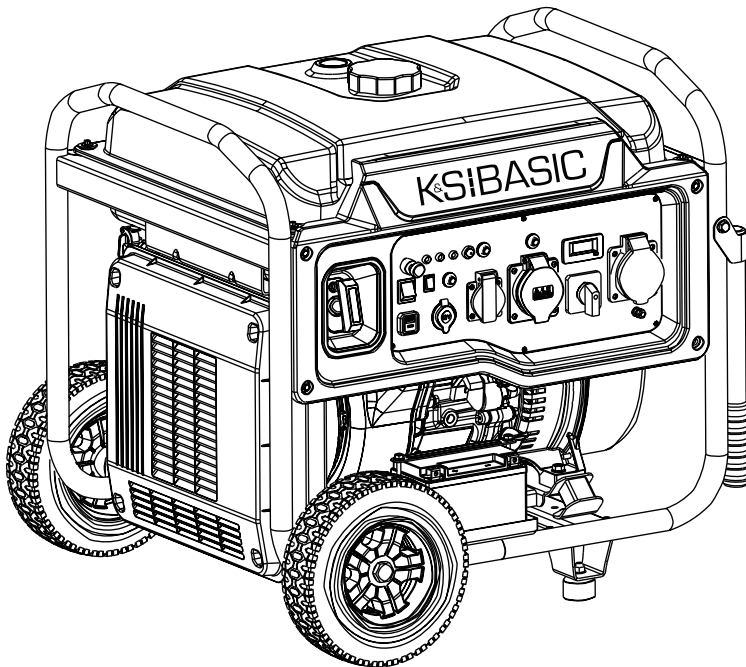



Thank you for choosing for **K&S Basic®** products. This manual provides a brief description of safety requirements, setup procedures, and operating instructions. More information is available in the support section at: **[konner-sohnen.com/pages/instructions](http://konner-sohnen.com/pages/instructions)**

You can also go to the support section and download the manual by scanning the QR code or on the website of the official importer of **K&S Basic!**® at **[www.konner-sohnen.com](http://www.konner-sohnen.com)**



*We care about the environment, therefore, we consider it expedient to save paper and leave in print a short description of the most important sections.*



**Be sure to read the full version of the manual before getting started!**



The manufacturer reserves the right to make changes that may not be reflected in this manual, including:

- The manufacturer reserves the right to make changes in the product design, configuration and construction.
- The images and drawings in this manual are for reference only and may differ from the actual components and inscriptions on the products.

Contact information for technical support is provided on the official website. All information in this manual is correct to the best of our knowledge and belief at the date of its publication. The current list of service centers can be found on the official importer's website at **[www.konner-sohnen.com](http://www.konner-sohnen.com)**



**ATTENTION – DANGER!**



**Failure to follow the recommendations marked with this sign may lead to serious injury or death of the operator or third parties.**



**IMPORTANT!**



**Useful information while operating the machine.**

## SAFETY INFORMATION

1

Do not use the generator in rooms with poor ventilation or in conditions of excessive humidity. Do not place the generator in water or on moist soil. Do not expose the generator to rain, snow, as well as to direct sunlight for a long time. Place the generator on a flat, hard surface, away from flammable liquids/gases (at a minimum distance of 1 m). Install the generator at a distance of not less than 1 m from the front control panel and not less than 50 cm on each side, including the upper part of the generator. Keep unauthorized persons, children, and animals away from work area. Wear safety shoes and gloves.



**ATTENTION – DANGER!**



**When using the generator, attention must be paid to the actual power consumption of the connected electrical devices, including the power factor (cosφ) and the starting power, which for devices with motors can be several times higher than the rated power and must not exceed the maximum output of the generator.**



**ATTENTION – DANGER!**



**As exhaust gases contain poisonous carbon dioxide (CO<sub>2</sub>) and carbon monoxide (CO) gases which are dangerous for life, it is strictly forbidden to install the generator in residential buildings, premises connected to residential buildings by a common ventilation system, other rooms from which exhaust gases may enter living premises.**

## RESIDUAL RISKS

Despite all design and safety measures applied to this generator set, certain residual risks may still remain during its operation.

## NOISE EXPOSURE

The guaranteed sound power level of this generator does not exceed the limits established by Directive 2000/14/EC and applicable EU regulations.

However, prolonged exposure to noise, even within permitted limits, may cause discomfort or fatigue.

**Recommendation:** When working close to the running generator for extended periods, use approved hearing protection and avoid staying unnecessarily near the noise source.

## VIBRATION RISK

The generator is equipped with vibration-isolating mounts to reduce transmission of vibration to surrounding structures.

Nevertheless, continuous or improper operation may lead to operator discomfort or health effects associated with long-term vibration exposure (such as hand-arm vibration syndrome).

**Recommendation:** Operate the generator only on its vibration-damping supports and avoid prolonged contact with vibrating components.

## ENVIRONMENTAL HAZARDS

During fuel filling, oil change, or maintenance, spilled oil or fuel may cause environmental contamination.



**IMPORTANT!**



**Prevent any fuel or oil from entering soil, sewage systems, or water sources.**

In case of leakage or accidental spill, stop the engine immediately, collect the liquid with approved absorbent material, and dispose of it according to local environmental regulations.

## ELECTRICAL SAFETY

1.1



**ATTENTION – DANGER!**



**The device generates electricity. Follow safety precautions to avoid electric shock.**

Generators are designed as portable power sources and feature basic protection through insulation of live parts in accordance with DIN VDE 0100-410. Live cables are insulated from the generator frame (IT system with floating neutral). Electrical devices may only be connected directly to the generator's sockets without additional protective measures.



**IMPORTANT!**



**Connecting a distribution board for more than one electrical device may only be carried out by qualified electricians or electrically instructed persons, observing the relevant safety precautions.**



**IMPORTANT!**



**It is forbidden to connect to the generator devices which can generate current pulses and direct energy towards the generator (voltage stabilizers, devices with electronic brakes, on-grid and hybrid inverters, etc.).**

The generator and power consumers form a closed system, with elements affecting each other. This system is physically different from the public network since it is significantly affected by factors such as unbalanced phase load and non-linear current consumption by power consumers that can cause damage to the generator and power consumers connected to it.

**ATTENTION – DANGER!**

**Be careful. Do not operate the generator, if you are tired, under the influence of drugs or alcohol. Inattention may cause a serious injury.**

**IMPORTANT!**

**Using device for other purposes deprives the right for free warranty.**

## PRECAUTIONS WHEN WORKING WITH GASOLINE GENERATOR

# 1.2

Do not start the generator operation upon presence of electric load! Disconnect the load before you stop the engine. **Use only unleaded gasoline with an octane rating of 90–95 containing no more than 10% ethanol.** The use of kerosene or any other type of fuel is not allowed! Always follow the manufacturer's recommendations regarding the shelf life and storage of fuel. The fuel in the tank comes into contact with air, which can affect its quality. Over time, depending on the quality of the fuel, deposits may accumulate in the float chamber of the carburetor, which must be drained regularly to ensure the carburetor functions properly. If the generator is not used for an extended period of time, we recommend completely draining the gasoline from the carburetor and the tank via the drain screw on the carburetor to prevent the formation of deposits in the fuel system. Failure to follow these recommendations may lead to the damage of the carburetor.

**ATTENTION – DANGER!**

**Fuel contaminates the land and groundwater. Do not allow the leaking gasoline from the tank!**

### FIRE SAFETY

Keep a suitable fire extinguisher nearby when operating or servicing the generator.

Use only extinguishers suitable for flammable liquids and electrical equipment, such as:

- CO<sub>2</sub> (carbon dioxide) extinguishers
- Foam extinguishers (AFFF type)

Do not use water-based extinguishers on fuel or electrical fires.

Ensure personnel are trained in the proper use of fire extinguishers.

Each time you start the generator, inspect the battery cables to prevent sparking and possible fire. The batteries must be kept clean. Use only the recommended cables and connections during generator operation. Fuel and fumes generated during operation can be flammable and potentially explosive. Safety regulations require fully charged fire extinguishers to be kept within easy reach of the generator.

**ATTENTION – DANGER!**

**Always start and use the generator set in a well-ventilated area. It is prohibited to use the generator in an unprepared room (without calculated supply ventilation or a properly designed exhaust gas removal system).**

MODEL KSB 55i

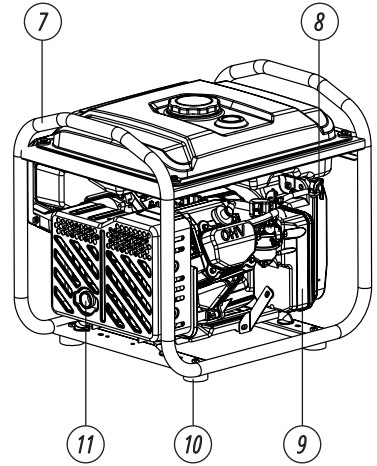
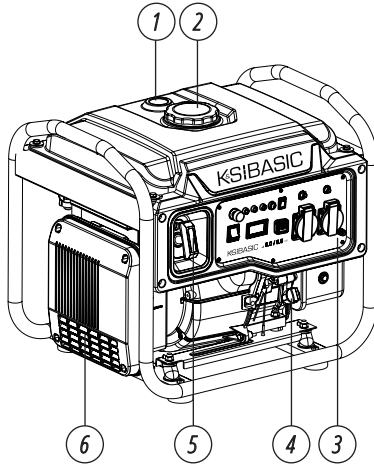

1. Fuel level indicator
2. Fuel tank cap
3. Control panel
4. Oil-depth gage
5. Manual starter
6. Ventilation grill

7. Frame
8. Fuel valve
9. Air filter cover
10. Antivibration supports
11. Muffler

CONTROL PANEL FOR MODEL KSB 55i

1. Air choke
2. Oil level indicator
3. Working mode indicator
4. Overload indicator
5. RESET button
6. Economy Mode switch
7. 16A AC circuit breakers
8. Earthing bolt
9. AC outlets 2xSchuko 230V
10. USB-Outputs 5V
11. LED-display (voltage, frequency, working hours)
12. Engine switch

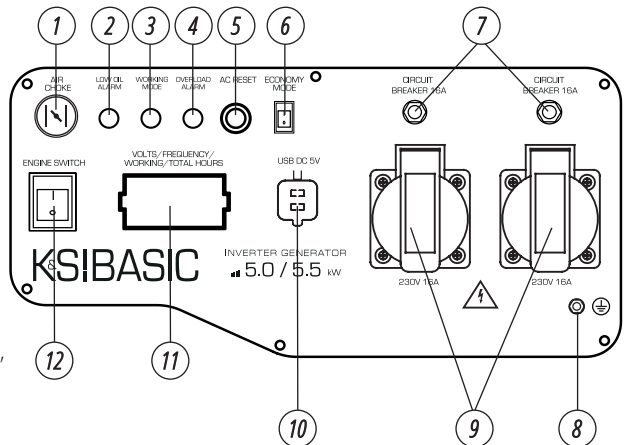

## MODEL KSB 80iE-1/3

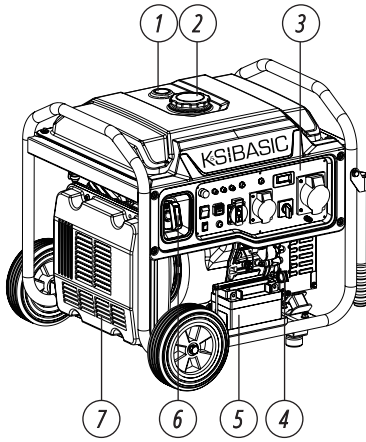

1. Fuel level indicator
2. Fuel tank cap
3. Control panel
4. Oil-depth gage
5. Battery
6. Manual starter

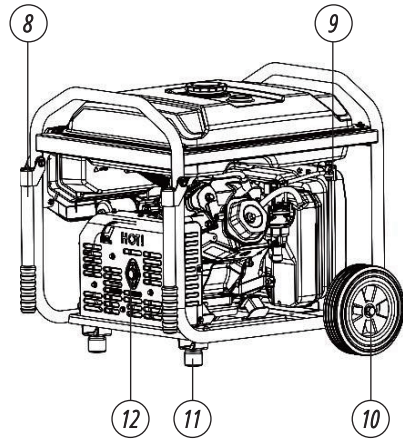

7. Ventilation grill
8. Transport handles
9. Fuel valve
10. Transport wheels
11. Antivibration supports
12. Muffler

## CONTROL PANEL FOR MODEL KSB 80iE-1/3

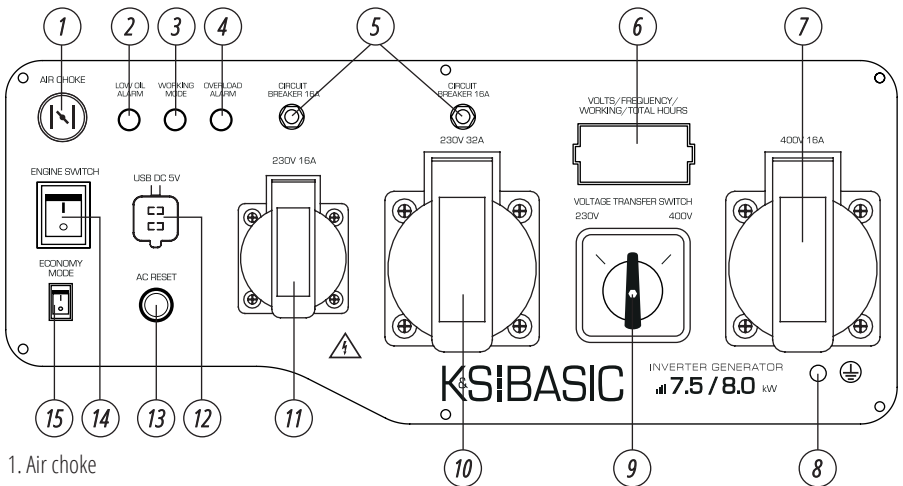

1. Air choke
2. Oil level indicator
3. Working mode indicator
4. Overload indicator
5. 16A AC circuit breaker
6. LED-display (voltage, frequency, working hours)
7. AC outlet CEE 400V 16A
8. Earthing bolt
9. VTS system single-/three phase switch (position 1 - 400V, position 0 (OFF) - disabled, position 2 - 230V)
10. AC outlet CEE 230V 32A
11. AC outlet Schuko 230V
12. USB-Outputs 5V
13. RESET button
14. Engine switch
15. Economy Mode switch

## MODEL KSB 110iE-1/3

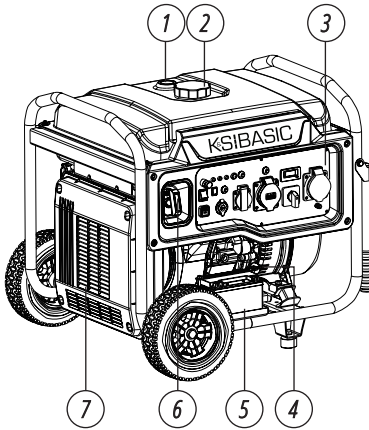

1. Fuel level indicator
2. Fuel tank cap
3. Control panel
4. Oil-depth gage
5. Battery
6. Manual starter

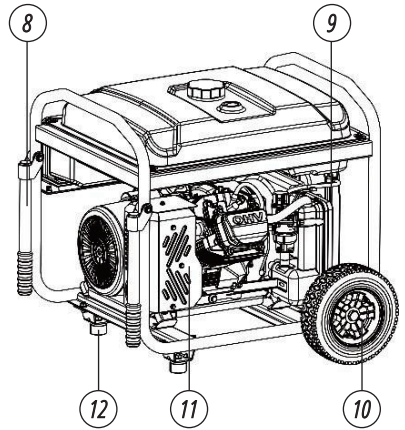

7. Ventilation grill
8. Transport handles
9. Fuel valve
10. Transport wheels
11. Muffler
12. Antivibration supports

## CONTROL PANEL FOR MODEL KSB 110iE-1/3

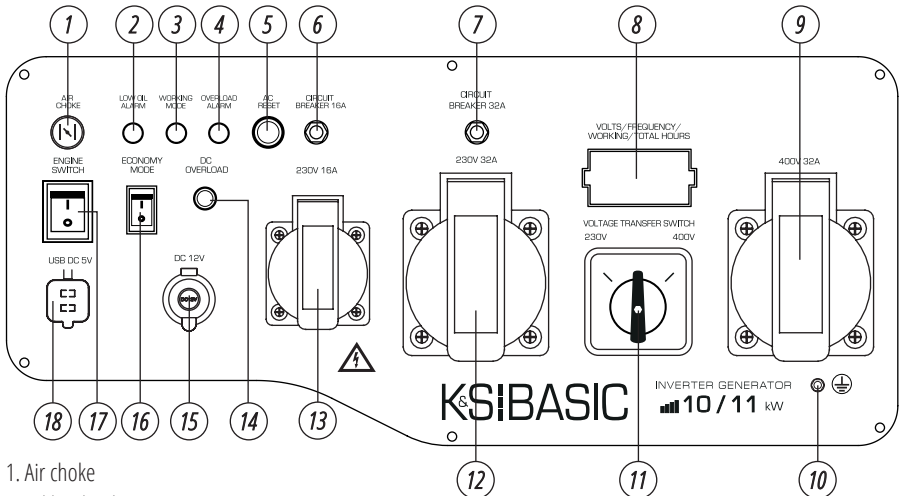

1. Air choke
2. Oil level indicator
3. Working mode indicator
4. Overload indicator
5. RESET button
6. 16A AC circuit breaker
7. 32A AC circuit breaker
8. LED-display (voltage, frequency, working hours)
9. AC outlet CEE 400V 32A
10. Earthing bolt
11. VTS system single-/three phase switch (position 1 - 400V, position 0 (OFF) - disabled, position 2 - 230V)
12. AC outlet CEE 230V 32A
13. AC outlet Schuko 230V
14. 12V DC fuse
15. 12V/8.3A DC outlet
16. Economy Mode switch
17. Engine switch
18. USB-Outputs 5V

## ACCESSORIES FOR MODEL KSB 55i

- Portable power plug 230V (16A) – 2 pcs.
- Spark plug wrench
- Tool case
- Oil funnel
- Open-end wrench

## ACCESSORIES FOR MODELS KSB 80iE-1/3, KSB 110iE-1/3

- Portable power plug 230V (16A)
- Portable power plug 230V (32A)
- Portable power plug 400V (16A) for model KSB 80iE-1/3
- Portable power plug 400V (32A) for model KSB 110iE-1/3
- Spark plug wrench
- Tool case
- Oil funnel
- Open-end wrench
- DC connection line for KSB 110iE-1/3

## SPECIFICATIONS

3

Model	KSB 55i		KSB 80iE-1/3		KSB 110iE-1/3	
<b>Voltage</b>	230 V		230 V	400 V	230 V	400 V
<b>Max power</b>	5,5 kW		8,0 kW	8,0 kW	11,0 kW	11,0 kW
<b>Nominal power</b>	5,0 kW		7,5 kW	7,5 kW	10,0 kW	10,0 kW
<b>Frequency</b>	50 Hz		50 Hz	50 Hz	50 Hz	50 Hz
<b>Current (max.)</b>	23,9 A		34,78 A	14,4 A	47,83 A	19,85 A
<b>Outlets</b>	Schuko 230V 16A		1×Schuko 230V 16A, 1×CEE 230V 32A, 1×CEE 400V 16A		1×Schuko 230V 16A, 1×CEE 230V 32A, 1×CEE 400V 32A	
<b>Engine start</b>	manual		manual/electric		manual/electric	
<b>Fuel tank volume</b>	12 l		25 l		40 l	
<b>LED display</b>	voltage, frequency, working hours					
<b>Noise level (Lwa)</b>	97 dB		97 dB		95 dB	
<b>Output 12V</b>	–		–		12V/8,3A	
<b>USB + Type C</b>	USB QC 3.0 + Type C					
<b>Engine model</b>	KSB 250i		KSB 430i		KSB 530i	
<b>Engine cylinder volume</b>	236 cm <sup>3</sup>		420 cm <sup>3</sup>		520 cm <sup>3</sup>	
<b>Engine type</b>	gasoline 4 stroke cycle engine					
<b>Engine power</b>	9 hp		15 hp		20 hp	
<b>Crankcase volume</b>	0,6 l		1,2 l		1,2 l	
<b>Power factor</b>	cos φ 1 (230V)		cos φ 1 (230V)	cos φ 0,8 (400V)	cos φ 1 (230V)	cos φ 0,8 (400V)
<b>Dimensions (L×W×H)</b>	540×435×475 mm		650×560×582 mm		810×570×600 mm	
<b>Battery</b>	–		9 Ah		11,2 Ah	
<b>Net weight</b>	34 kg		64 kg		84 kg	
<b>Protection class</b>	IP23M					
<b>Nominal voltage tolerance – max. 5%</b>						

To ensure reliability and increase the engine service life, peak powers may be slightly limited by circuit breakers. The optimal operating conditions are ambient temperature of 17-25°C, barometric pressure of 0.1 MPa (760 mm Hg), and relative humidity of 50-60%. Under these environmental conditions, the generator can provide maximum performance in terms of the declared specifications. In the event of deviations from these environmental indicators, the generator performance may vary.

Please note that continuous loads exceeding 80% of the generator's rated power are not recommended in order to extend its service life.



## EC Declaration of Conformity

### Inverter generator "K&S BASIC"

K&S BASIC® declares that these products described below  
**KSB 55i, KSB 80iE-1/3, KSB 110iE-1/3**

**Technical data** are in compliance with 2006/42/EC, 2014/30/EC, 2000/14/EC.

- EN ISO 8528-13:2016
- EN 55012:2007/A1:2009
- EN IEC 61000-6-1:2019
- EN ISO 3744:2010
- EN ISO 8528-10:2022

These products also comply with 2006/42/EC Machinery Directive, 2014/30/EC Electromagnetic compatibility Directive (EMC), 2000/14/EC Noise Directive.

For more information, please contact K&S BASIC® at the following address or refer to the back of the manual.

The undersigned is responsible for compilation of the technical file and makes this declaration on behalf of K&S BASIC®.

P. Fomin  
 Director, 8 Flinger Broich 203, 40235 Duesseldorf, Germany:  
 25.03.2026

**DIMAX**  
 International GmbH  
 Flinger Broich 203 40235 Düsseldorf  
 USt-ID DE296177274  
 koenner-soehnen.com

### REACH REGULATION (EC) NO. 1907/2006

The manufacturer confirms that this product complies with the requirements of the REACH Regulation concerning the restriction of substances of very high concern (SVHC). We confirm that supplied parts comply with REACH Regulation (EC) 1907/2006 and contain no SVHC above 0.1%

Based on information received from component suppliers, no SVHC are present in concentrations exceeding the limits defined by the regulation.

This declaration is made on the basis of self-assessment and supplier statements.

### ROHS DIRECTIVE 2011/65/EU

This product contains electrical and electronic components that are subject to the RoHS Directive 2011/65/EU.

Based on information and test reports provided by component suppliers, the manufacturer confirms that these components comply with RoHS Directive 2011/65/EU.

## TERMS OF USE OF INVERTER GENERATOR

4

Before starting the device, remember that the total power of the connected power consumers should not exceed the nominal power of the generator.

**IMPORTANT!**

**Inverter generators produce 230 V at 50 Hz and must not be used as a replacement for the main power grid when powering devices designed to feed energy into the electrical grid (such as grid-tied inverters, hybrid inverters, microinverters, etc.). These devices may detect the 230 V 50 Hz output from the inverter generator as the main power supply and can damage the generator through backfeeding.**

**IMPORTANT!**

**Make sure that the control panel, the blinds and the underside of the inverter are well cooled and protected against the ingress of small solids, dirt, and water. Improper operation of the cooler can cause damage to the motor, inverter or alternator.**

**GENERATOR OPERATION****5****OIL LEVEL INDICATOR (RED)**

The low oil indicator lights up when the oil level is too low. The ignition is deactivated and the engine stops. The engine will not start until oil is added.

**AC INDICATOR**

When the generator is running and producing electricity, the AC indicator light is on.

**RUN/OVERLOAD**

When the generator is running normally, the AC lights up green. If there is an abnormality in the generator, the AC flashes red, the machine automatically protects and cuts off the output. Need to press the AC to reset.

The overload indicator lights up when the connected generator is overloaded, the inverter control unit overheats or the AC output voltage rises. If the overload indicator goes on, the engine will continue to operate, but the generator will no longer produce electricity. In this case, you must perform the following steps:

1. Turn off all connected electrical appliances and stop the engine.
2. Reduce the total power of the connected devices until the nominal power of the generator is reached.
3. Check if the vent grid is clogged. Remove excess dirt or debris, if any.
4. After checking, start the engine.

**IMPORTANT!**

**The overload indicator may light up within several seconds after start-up or when connecting electrical devices requiring a high starting current, such as a compressor or voltage indicator. However, this is not a malfunction.**

**EARTHING BOLT**

Depending on the installed network, the generator's grounding screw must be connected either to the equipotential bonding bar (IT network) or to the grounding system (TN network). **The generator is built as an IT system (isolated terra) and has no internal connection between N and PE.** Grounding of the generator is not required for mobile applications and direct power supply to electrical loads. Grounding the generator or equipotential bonding via the grounding screw is not required for mobile applications and direct power supply to electrical loads. Equipotential bonding between the generator and the electrical loads is achieved via the PE contact of the sockets and the corresponding conductors of the power cables. Connection of the external distribution should only be carried out by a qualified electrician, observing all prescribed safety precautions.

It is the responsibility of a trained electrician to follow national regulation to properly assess the correct installation type.

**Any modification to bond Neutral to Earth must only be performed by a qualified electrician in accordance with local regulations.**

## DC OVERLOAD PROTECTION

The DC protector automatically switches to “OFF” when the current of the operating electrical device is higher than the rated current. To use this equipment again, turn on the DC OVERLOAD breaker.



**IMPORTANT!**



**If the DC OVERLOAD breaker turns off, reduce the load of the connected electrical device. If the DC OVERLOAD breaker turns off again, stop operation and contact your service center.**

## CHECK BEFORE GETTING STARTED

6

### CHECKING THE FUEL LEVEL

1. Unscrew the fuel cap and check the fuel level in the tank.
2. Fill the fuel tank to the fuel filter level.
3. Tighten the fuel cap securely.

**Recommended fuel:** unleaded gasoline with an octane rating of 90–95 containing no more than 10% ethanol.

**Fuel tank volume:** see specifications table.



**IMPORTANT!**



**Wipe up spilled fuel immediately with a clean, dry, soft cloth, as the fuel may harm painted surfaces or plastic parts.**



**IMPORTANT!**



**Be sure to observe the expiration date of the gasoline. If the generator is not going to be used for an extended period, always drain the gasoline from the carburetor and, if necessary, from the fuel tank. Deposits in the fuel system can lead to engine malfunctions.**

### CHECKING THE OIL LEVEL

The generator is transported free of motor oil. Do not start the engine until it is filled with sufficient amount of motor oil.

1. Unscrew the oil dipstick and wipe it out with a clean cloth (Fig. 1).
2. Fill the crankcase with engine oil. The recommended amount of oil for each model is indicated in the specification chart.
3. Insert the dipstick without screwing it in.
4. Check the oil level by a mark on the oil dipstick.
5. Add oil if its level is below the mark on the oil dipstick.
6. Screw on the dipstick.

**Recommended motor oil:** SAE 10W30, SAE 10W40.

**Recommended motor oil grade:** API Service SG type or higher.

**Motor oil quantity:** see specifications table.

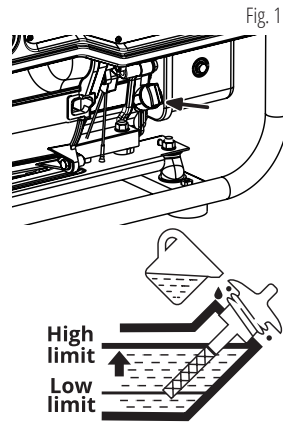

Fig. 1

## GETTING STARTED

7

**Before starting the engine, make sure that the rated power of power consumers matches with the power of generator. Do not exceed the nominal power of the generator. Do not connect any devices before you start the engine!**



**IMPORTANT!**



Do not change the controller settings in terms of the amount of fuel or speed governor (this adjustment was made at the factory). Otherwise, this may result in changes in the engine operation or its failure.



**ATTENTION – DANGER!**



When drawing power between the rated and maximum power levels, the generator must not run for longer than 5 seconds. This is common, for example, when starting the electric motor. The required starting power of the motor must not exceed the maximum starting power of the generator.



**ATTENTION – DANGER!**



Standby generators should not run continuously (e.g. by adding fuel to the tank or connecting a large fuel tank) or longer than recommended: 4-6 hours for gasoline generators (depending on load).

This material is for informational purposes only and does not constitute a manual for installing the equipment or connecting it to the mains, but we strongly recommend that you read the instructions below. Equipment connection must always be carried out by a certified electrician responsible for the installation and electrical connection of the equipment according to local laws and regulations. The manufacturer assumes no liability for improper connection of the equipment or for any material or physical damage that may result from improper installation, connection or operation of the equipment.

## COMMISSIONING

1. Fill the crankcase with engine oil. The recommended amount of oil for each model is indicated in the specification chart.
2. Check oil level with an oil dipstick. It should be between the MIN and MAX marks on the oil dipstick.
3. Check fuel level.
4. Check the air filter for correct installation.

## IN THE FIRST 20 OPERATING HOURS OF THE GENERATOR, THE FOLLOWING REQUIREMENTS SHOULD BE MET:

1. During commissioning, do not connect power consumers, the power of which exceeds 50% of the nominal (operating) power of the device.
2. After the first 20 operating hours, be sure to change the oil. It is better to drain oil while the engine is still hot after operation to ensure quick and complete oil draining.
3. Check and clean the air filter, fuel filter and spark plug.

## ENGINE START



**IMPORTANT!**



**Useful tip:** If the engine stalls shortly after starting or does not start at all, we recommend draining deposits from the carburetor and checking the oil level. The generator is equipped with a low oil level indicator, and the engine will stop if the engine oil level is too low.



**IMPORTANT!**



Deposits from the carburetor's float chamber should be drained regularly. If the generator is not going to be used for an extended period, close the fuel tap and drain the gasoline from the carburetor to prevent possible deposits from forming inside the carburetor.

1. Check oil level.
2. Check fuel level.
3. Set all circuit breakers to "OFF"
4. Set ECOMONY MODE button to "OFF" position (Fig. 2).
5. Open fuel valve ("ON" position, Fig. 3).
6. Close the choke ("OFF" position, Fig. 4).
7. Set ENGINE SWITCH button to "ON" Position (Fig. 5).
8. Pull the manual starter until a slight resistance is felt, then pull it toward you relatively sharply. Slowly return the manual starter by hand, do not release it abruptly.
9. Open the choke ("ON" position).
10. Wait 1-2 minutes and connect electrical appliances.
11. Set circuit breakers to "ON" one by one.

Fig. 2



Fig. 3



Fig. 4

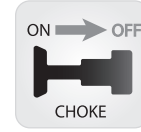
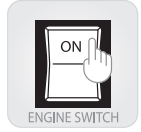

Fig. 5



**IMPORTANT!**



**Useful tip: to ensure long-term operation of the generator engine, it is important to observe the following tips:**

- Before connecting the load, allow the engine to run for 1-2 minutes to warm it up.
- When disconnecting the load after lengthy operation, do not turn off the generator. Allow the generator to run idle for 1-2 minutes so that it cools down.



**ATTENTION - DANGER!**



**Do not connect two or more devices at a time. The start-up of many devices requires high power. Devices should be connected one at a time according to their power rating.**

## DISCONNECT ALL DEVICES BEFORE STOPPING THE GENERATOR!

Do not stop the generator with the devices turned on. This may disable the generator or devices connected to it!

## TO STOP THE ENGINE, PROCEED AS FOLLOWS:

1. Set all circuit breakers to "OFF".
2. Turn off all devices.
3. Allow the generator to run idle for approx. 1-2 minutes.
4. Set ECOMONY MODE button to "OFF" position (Fig. 6).
5. Set the ENGINE SWITCH to the "OFF" position (Fig. 7).
6. Close the fuel valve ("OFF" position).
7. Allow the generator to cool down. Unplug the devices.

Fig. 6



Fig. 7

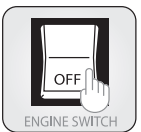

## BATTERY – CONNECTION & MAINTENANCE

8



**IMPORTANT!**



**During the initial startup, the negative terminal of the battery must be connected.**

The generator is shipped with terminals disconnected to prevent battery self-discharge during storage. To connect the battery terminals, proceed as follows:

Connect the terminals ensuring the correct polarity ("+" to "+», "-" to "-").

For models with electric start, check if the battery is charged. If necessary, recharge the battery with a dedicated charger for lithium-ion batteries or start the generator with a manual start and allow it to run idle while it is recharging.

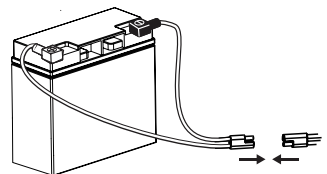

Models with electric start are equipped with a starter battery. Before first use, connect the negative terminal (battery is shipped disconnected to prevent self-discharge). The battery is automatically charged while the generator is running; if the generator is used infrequently or the charge level is low, recharge it via the battery charging port using a suitable charger (max. 14–14.5 V, with reverse polarity protection, e.g., KS-B2A). Avoid repeated start attempts to prevent starter overheating. For storage, fully charge the battery, disconnect the negative terminal, and recharge at least every 1–3 months to maintain the charge above 60%.



**ATTENTION – DANGER!**



**Never smoke or interrupt battery connections to the generator while the battery is being charged.**

## BATTERY HANDLING. PREPARATION FOR LONG-TERM STORAGE

If the generator is not used for an extended period (more than one month), the battery must be prepared for storage:

### Disconnect the battery:

1. Turn off the generator and make sure all systems are de-energized.
2. First disconnect the negative (–) terminal, then the positive (+) terminal of the battery.
3. If necessary, remove the battery from the generator for separate storage.

### Clean the terminals:

1. Wipe the terminals with a dry cloth and remove any oxidation if present.
2. Optionally, apply a thin layer of technical grease to the terminals to prevent corrosion.

### Storage conditions:

1. Store the battery in a dry, clean, and well-ventilated area at a temperature between +5 °C and +25 °C.
2. Avoid direct sunlight and exposure to moisture.

### Maintaining the charge:

1. Fully charge the battery before storage.
2. If the battery is stored for more than 3 months, it is recommended to recharge it every 2–3 months to full capacity.

### Returning the battery to operation:

Before reinstalling the battery on the generator:

1. Check the charge level and recharge if necessary.
2. Inspect the casing and terminals for any damage or corrosion.
3. Connect the battery starting with the positive (+) terminal, then the negative (–) terminal.
4. Ensure all connections and mounts are secure.

## BATTERY MAINTENANCE

In **K&S Basic**® models with electric start, you should periodically perform battery voltage checks. The generator battery has a voltage of 12V, if the voltage is lower, you should perform battery charging with the help of an external charger (not included in the delivery set).

To avoid discharging the battery, it is recommended to run the generator at least once a month for 30 minutes. If the generator is not used for a long time, please disconnect the battery from the terminals. The battery that comes with the generator does not require additional maintenance or filling of electrolyte.

If the generator is not used for a long time, the battery may fail. To prolong battery life it is recommended to do battery charging with an external device (not included) every three months.

Battery warranted - three months from the date of purchase of the generator.



**IMPORTANT!**



**Please note that if you fail to start up generators, the batteries may run out; therefore, the batteries must be fully charged before starting operation.**

### ECONOMY MODE FUNCTION

**Start the generator with Economy Mode OFF. Activate it only after the engine stabilizes and when the load is low (up to approx. 20% of rated power) to reduce fuel consumption and noise. Switch Economy Mode OFF when connecting high starting current devices, increasing load, during parallel operation, or when charging a battery via 12V DC to avoid overload or voltage instability.**

### MODELS WITH VTS SYSTEM

Models named "1/3" are equipped with a VTS phase switching system. These models can operate in single-phase (230V) and three-phase (400V) without loss of power.



**IMPORTANT!**



**You must first switch off the load before switching between 230V and 400V mode.**

### USING THE THREE-PHASE MODE 400V

The 400V mode is only available on 1/3 models. The entire power of the generator is divided between 3 phases in 400V mode, so that no more than 1/3 of the total power of the generator is available on each phase. Each phase of the 400V output is supplied by a separate inverter module and the generator is therefore suitable for unbalanced loads. Please pay attention to the starting currents of the power consumers to be supplied. The starting power must not exceed the maximum power per phase.



**ATTENTION – DANGER!**



**If the generator's overload protection is triggered due to an overload, be sure to reduce the load and then press the AC RESET button or restart the generator.**

### CHARGING AN EXTERNAL 12 V BATTERY

1. Start the engine.
2. Connect the red wire to the positive (+) terminal of the battery.
3. Connect the black wire to the negative (-) terminal of the battery.
4. Connect the wire to a 12V/8A DC socket on the control panel of the generator.
5. To start charging the battery, set Economy Mode to "OFF".
6. Turn the 12 V DC fuse to the "ON" position.



**IMPORTANT!**



**The 12V socket can only be used as a backup source for recharging batteries and shall not be deemed as a full-featured battery charger.**

If the DC overload protection trips, stop charging the battery because the charging current is too high. Do not charge batteries if their current consumption is more than 5-8 A (depending on the generator model).



**ATTENTION – DANGER!**



**The 12V connection on the generator is designed only as an emergency power source for 12V batteries and must not be used as a 12V power source for sensitive 12V power consumers.**

## TECHNICAL MAINTENANCE WORKS

Unit	Action	At each start	First month or 20 operating hours	Every 3 months or 50 operating hours	Every 6 months or 100 operating hours	Every year or 300 operating hours
Motor oil	Level check	✔				
	Replacement		✔	✔		
Air filter	Check /Cleaning	✔	✔	✔		
	Replacement				✔	
Spark plug	Cleaning		✔	✔		
	Replacement				✔	
Fuel tank	Level check	✔				
	Cleaning					✔
Fuel filter	Check (clean out)		✔	✔		
	Replacement				✔	

- If the generator often operates at high temperature or high load, the oil should be replaced every 25 operating hours.
- If the engine often runs in dusty or other harsh conditions, clean the air filter every 10 operating hours.
- If you missed the maintenance time, perform it as soon as possible to save the generator engine.



**IMPORTANT!**



**The manufacturer shall not be liable for any damage caused by failure to perform maintenance work.**

## RECOMMENDED OILS

11

Use oils designed for four-stroke cycle vehicle engines SAE10W-30, SAE10W-40. Motor oils with other viscosity levels, may be used only if the average air temperature in your region does not exceed the limits of the temperature range, specified in the table.

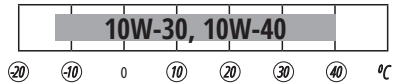

Upon oil level decrease it is necessary to add the required quantity in order to provide the correct generator operation. It is necessary to check the oil levels according to technical maintenance schedule. The detailed description of oil filling and draining can be found in the full version of the manual.

### ENGINE OIL REPLACEMENT OR ADDING



**ATTENTION – DANGER!**



**Do not drain engine oil immediately after stopping the generator. The oil will be too hot. It's dangerous! Allow the engine to cool slightly, and drain the warm oil. Oil will drain faster and easier from a warm engine.**

1. Please drain the oil while the engine is warm. This provides a quick and complete oil drain.
2. Wear protective gloves to avoid getting oil on the skin.
3. Place a drain oil holding tank under the engine.
4. Turn the drain cap, located in the engine under the oil-depth gage cap, by means of spanner.
5. Wait till the oil drains.
6. Replace the drain cap and tighten it well.

**TO REFILL OIL, PERFORM THE FOLLOWING ACTIONS:**

1. Make sure that the generator is set on flat level surface.
2. Open the oil-depth gage cap on the engine
3. By means of a funnel, pour the advanced purification engine oil to the crankcase.

**ATTENTION – DANGER!**

**Do not tilt the generator when topping up engine oil. This can cause the crankcase to overflow and damage the engine. Make sure that foreign objects do not get into the crankcase.**

**AIR FILTER TECHNICAL MAINTENANCE****12**

Air filter cleaning is to be performed each 50 hours of the generator operation (every 10 hours in unusually dusty conditions).

**CLEANING THE FILTER:**

1. Open the clips on the upper cap of the air filter.
2. Remove the sponge filtering element.
3. Remove all dirt deposits inside the hollow case of the air filter.
4. Thoroughly wash the filtering element in warmsoapy water.
5. Dry the sponge filter.
6. Dry filtering element is to be moistened by motor oil and excess oil is to be squeezed out.

**SPARK PLUGS TECHNICAL MAINTENANCE****13**

Spark plug has to be intact, without soot deposits and to have a correct gap.

**SPARK PLUG VERIFICATION:**

1. Remove the cap from the spark plug.
2. Remove the spark plug by means of a corresponding spanner.
3. Examine the spark plug. If it is shattered – it is necessary to replace it.  
Recommended replacement spark plugs: BPR6ES/BP6ES(NGK), F6RTC/F6TC (TORCH).
4. Measure the gap. It has to be within range 0.6 – 0.7 mm.
5. In case of repeated use, the spark plug has to be cleaned by means of a metal brush.  
After that – set the correct gap.

**DAMPER AND FLAME ARRESTER MAINTENANCE****14**

The engine and damper will get very hot after the generator has been started. Do not touch the engine or damper with any part of your body or clothing during inspection or repair until they have cooled down.

Remove the screws and then pull the protective cover towards you. Loosen the bolts and remove the cover, screen and flame arrester of the damper. Descale the screen and flame arrester of the damper with a wire brush. Inspect the screen and flame arrester of the damper. Replace them if they are damaged. Replace the flame arrester. Replace the screen and cover of the damper. Replace the cover and tighten the screws.

**IMPORTANT!**

**Match the protrusion of the flame arrester to the hole in the pipe damper.**

**IMPORTANT!****Never use gasoline while smoking or in the immediate vicinity of an open flame.**

1. Remove the fuel tank cap and fuel filter.
2. Clean the filter with gasoline.
3. Wipe the filter and replace it.
4. Replace the fuel tank cap.
5. Make sure that the fuel tank cap is tight.

Storage room has to be dry and free from dust deposits. Storage room also has to be locked away from children and animals. It is recommended to store and use the generator at temperature of -20°C to +40°C. Avoid direct sunlight, rain on the generator.

**IMPORTANT!****Warning! Generator is to remain ready for operation at all times. Therefore in case of device malfunctions, they are to be repaired before dismantling the generator for storage.****IMPORTANT!****Before long-term storage of the generator during the engine work close the fuel valve and let the engine to elaborate gasoline from carburetor. Wait until engine stops itself.****BEFORE LONG-TERM GENERATOR IDLE TIME – PERFORM THE FOLLOWING ACTIONS:**

- Generator and engine external parts (especially the cooling radiators) are to be thoroughly cleaned.
- Carburetor float chamber screw has to be removed and the chamber – drained.
- Remove the spark plug.
- Oil drain screw is to be removed and the oil – drained.
- Pour one teaspoon of motor oil to the cylinder (5-10 ml). After that – pull the starter cord for a few times, to let the oil equally distribute on the cylinder walls.
- Install the spark plug.
- Pull the starter handle until you feel the resistance. to let the piston relocate to the upper pressure tact point.
- Smoothly release the starter handle.
- Remove the battery terminals. Grease the battery terminals and connecting terminals with grease to protect against oxidation (if model equipped with fuel filter).

**IMPORTANT!****We recommend filling the fuel tank only 70% to avoid fuel spillage during generator operation and transportation .**

For easy generator transportation use packaging, which generator was sold in. Secure the box with the generator so that it does not tip over during transportation. Before moving the generator drain the fuel and disconnect the terminals of the battery. Keep the generator upright. Never place the generator on its side or upside down!

To move the generator from one place to another lift it by holding the frame. Be careful - the generators are heavy (40 to 90 kg). At least two men are needed to move the generator. Be careful, do not expose your feet under the frame of the generator.

**WEEE DIRECTIVE COMPLIANCE (2012/19/EU)**

This product is subject to the European Directive 2012/19/EU on Waste Electrical and Electronic Equipment (WEEE). The inverter generator must not be disposed of together with household waste. At the end of its service life, the product must be taken to an authorized collection point for electrical and electronic equipment for proper treatment, recovery, and recycling. The generator housing is made of plastic and should be recycled in accordance with local regulations. The packaging materials, including the cardboard box, are recyclable and should be disposed of through appropriate recycling systems.



**BATTERY SAFETY**

- Used batteries must be disposed of in accordance with local environmental regulations.
- Do not dispose of batteries in fire or with household waste.
- Improper handling of batteries may cause leakage, fire, or explosion.
- Always replace batteries with the same type and specification recommended by the manufacturer.
- Avoid short-circuiting battery terminals.

**POSSIBLE FAILURES AND SOLUTIONS**

Typical failures	Possible reason	Solution
<b>Engine does not starting</b>	Engine starting swinch set to OFF position	Set the engine starting switch to ON
	Fuel valve set to off position	Turn the valve to ON position
	Air flap is opened	Shut the air flap
	No fuel	Add fuel
	Low-quality or dirty fuel is in engine	Change the fuel
	Sparking plug smoked or corrupted distance between contacts is not nominal	Clean or replace the plug; set proper distance between contacts
<b>Low engine power / heavy starting</b>	Dirt in fuel tank	Clean the fuel tank
	Dirt in the air filter	Clean the air filter
	Water in a fuel tank/ carburetor; carburetor is jammed	Empty the fuel tank, carburetor
	Distance between contacts of a sparking plug is not nominal	Set proper distance between contacts
<b>Engine overheated</b>	Cooling fins are dirty	Clean the cooling fins
	Air filter is dirty	Clean the air filter
<b>No voltage while working engine</b>	Circuit breaker is active	Turn on the cricuit breaker
	Connected cables are corrupted	Check the cables; if using extension cord, change it
	Plugged device failure	Try to connect other devices
<b>Connected devices are not working while generator is running</b>	Generator is overloaded	Unplug some devices to reduce load
	Short circuit occured in one of the devices connected	Unplug that device to restore the stability of a system
	Air filter is dirty	Clean the air filter
	Repetitions of an engine are lower than nominal	Contact the service center

The international manufacturer warranty is 1 year. The warranty period starts from the date of purchase. In cases when warranty period is longer than 1 year according to local legislation please contact your local dealer. The Seller which sells the product is responsible for granting the warranty. Please contact the Seller for warranty. Within the warranty period, if the product fails because of defects in the production process, it will be exchanged on the same product or repaired.

All faults caused by the manufacturer during the warranty period will be eliminated free of charge. Warranty repair is carried out only if you have a fully completed warranty card, the Buyer's signature of acceptance of the warranty terms, as well as a document supporting the purchase (cash receipt, sales slip or invoice). In the absence thereof, as well as in the event of errors or corrections not authenticated by the seller's seal or illegible inscriptions in the warranty card or tear-off coupon, no warranty repair is carried out, no objections to quality are accepted and the warranty card is withdrawn by the service center as invalid. The device is accepted for repair clean and full.

#### WARRANTY DOES NOT COVER:

- If the user has failed to comply with the instructions in this manual.
- If the product features damaged or missing identification stickers or labels, serial numbers, etc.
- If product malfunction was due to improper transportation, storage and maintenance.
- In case of mechanical damages (cracks, chips, impact and fall marks, deformation of housing, power cord, plug or any other components), including those resulting from the freezing of water (ice formation), provided there are foreign objects inside the unit.
- If the product has been improperly installed and connected to the mains supply or misused.
- If the claimed malfunction cannot be diagnosed or demonstrated.
- If proper operation of the product can be restored following cleaning from dust and dirt, appropriate adjustment, maintenance, oil change, etc.
- If the product is used for business related purposes.
- If faults are detected, which have been caused by product overload. Signs of overload are molten or discolored parts as a result of high temperatures, damaged cylinder or piston surfaces, degraded piston rings or connecting rod bushes.
- The warranty does not cover the failure of the product automatic voltage regulator due to careless handling or mishandling.
- If faults are detected, which have been caused by instability of the user's power grid.
- If there are faults caused by contamination or fouling such as contamination of the fuel, oil or cooling system.
- If electrical cables or plugs show signs of mechanical or thermal damage.
- In the event of foreign liquids and objects, metal chips, etc. inside the product.
- If the malfunction is caused by the use of non-original spare parts and materials, oils, etc.
- If there are two or more faulty units that are not interconnected.
- If the damage was caused by natural factors such as dirt, dust, humidity, high or low temperature, natural disasters.
- In case of simultaneous failure of the rotor and stator.
- For wear parts and accessories (spark plugs, nozzles, pulleys, filter and safety elements, batteries, detachables, belts rubber seals, clutch springs, axles, hand starters, grease, mountings, working surfaces, hoses, chains, and tires).
- To preventive maintenance (cleaning, greasing, washing), installation and adjustment.
- If the product was tampered with, independently repaired or modified.
- In case of malfunctions resulting from normal wear and tear as a result of long-term use (end of life).
- If product operation was not stopped and continued after detecting a malfunction.
- Batteries supplied with equipment are covered by a warranty of three months.
- When using low-grade or inappropriate fuel.

## CONTACTS

**Deutschland:**

Hergestellt unter Lizenz und Kontrolle der DIMAX International GmbH.

Importeur und Vertreter in Deutschland:  
DIMAX International GmbH, Flinger Broich 203,  
40235 Düsseldorf, Deutschland. Produziert in VRC.  
amazon@dimaxgroup.com  
[www.konner-sohnen.com](http://www.konner-sohnen.com)

---

**European Union:**

Manufactured under license and control of DIMAX International GmbH, Flinger Broich 203, 40235 Duesseldorf, Germany.

Importer and representative in Netherlands DIMAX International Poland Ltd, Południowa 8 st, 05-830 Stara Wieś, Poland. Assembled in PRC.  
amazon@dimaxgroup.com  
[www.konner-sohnen.com](http://www.konner-sohnen.com)

---

**France:**

Fabriqu e sous licence et contr ole de DIMAX International GmbH, Flinger Broich 203, 40235 D usseldorf, Allemagne.

Importateur et repr esentant en France et en Belgique DIMAX International Poland Ltd, Południowa 8 st, 05-830 Stara Wieś, Pologne. Assembl e en RPC.  
amazon@dimaxgroup.com  
[www.konner-sohnen.fr](http://www.konner-sohnen.fr)

---

**España:**

Fabricado bajo licencia y control de DIMAX International GmbH, Flinger Broich 203, 40235 D usseldorf, Alemania.

Importador y representante en Espa a de DIMAX International Poland Ltd, Południowa 8 st, 05-830 Stara Wieś, Polonia.  
Ensamblado en la Rep blica Popular China.  
amazon@dimaxgroup.com  
[www.konner-sohnen.es](http://www.konner-sohnen.es)

---

**Polska:**

Wyprodukowano na licencji i pod kontrol a DIMAX International GmbH, Flinger Broich 203, 40235 Duesseldorf, Niemcy.

Importer i przedstawiciel w Polsce:  
DIMAX International Poland Sp.z o. o. ul. Południowa 8,  
05-830 Stara Wieś, Polska. Zmontowany w CRL.  
amazon@dimaxgroup.com  
[www.konner-sohnen.pl](http://www.konner-sohnen.pl)

---

**Україна:**

Виготовлено за ліцензією та під контролем DIMAX International GmbH, Flinger Broich 203, 40235 Дюссельдорф, Німеччина.

Імпортер та представник в Україні:  
ТОВ "ТЕХНО ТРЕЙД КС" вул. Електротехнічна 47,  
02225, м. Київ, Україна. Змонтовано в КНР

[www.konner-sohnen.com.ua](http://www.konner-sohnen.com.ua)

